

Hit!

FOBA easel – stepless, precisely adjustable height

FOBA is a leading supplier of complete photo studio equipment. Among other products FOBA also offers special products for museums.

The easel shown on the right is used in museums to make photographs of their works of art or for the analysis of paintings with a binocular eyepiece.

Easy to use

The work of art is clamped between two horizontal rails. The upper rail can be moved up and down continuously and locked into position. In this way pictures of various formats of up to 135 cm height can be processed. Without effort, the photographer or conservator can work easily at his usual height thanks to the continuously adjustable height of the entire picture.

Various possibilities

The easel is assembled on a stand of any height (based on the studio stand ASABA). This stand can be attached either to a mobile cast-iron base or secured to the floor or wall.

The camera or binocular eyepiece is assembled on another stand. This stand can then be moved exactly perpendicularly to the easel thanks to a rail attached on the floor.

All products are in black, non-reflexing color.

Rail attached to the floor with millimeter division and manual lock: Thanks to the millimeter scale a precise position can be repeated (MUFUS: cast-iron base for rail).

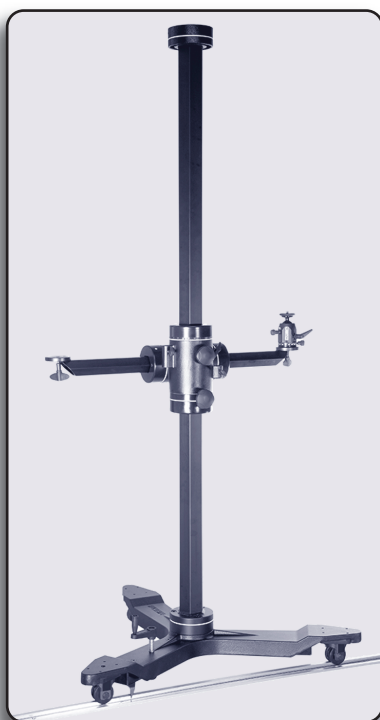

Easel on an ASABA stand and FOBA cast-iron base (MUSTA)
Height: 2.5 m
Weight: 101 kg



Binocular eyepiece on stand for the analysis of a work of art.

Easel (MUSEA) for upright attachment of pictures; upper rail steplessly adjustable on ball bearings; whole easel steplessly adjustable on stand with 24 ball bearings. A counterweight (17.5 kg) is attached to a snap-hook on the end of the cable inside the column, which helps to hold the easel and picture in balance. This way it can easily be moved up or down on the stand and secured. In case of regular work with heavy pictures (8 kg and more) additional counterweights of 3 kg each (ASOBO) can be built into the column.

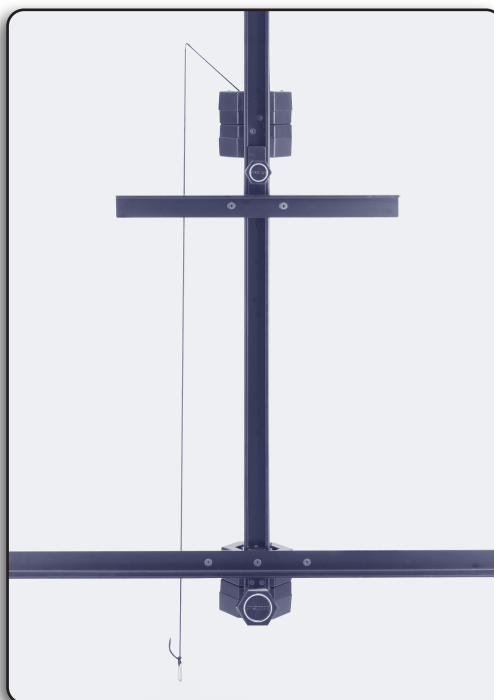

Upper rail:	60 cm
Lower rail:	120 cm
Picture height:	10 cm to max. 135 cm
Length:	158 cm
Weight:	13 kg

Can protrude from the upper edge of the shaft up to 47 cm (18.5").

Custom designs available on request.



Easel on cast-iron base

A clever mechanism allows raising and moving the entire stand on rolls with rotating pedal or to lower the stand and secure it on the floor with hardly any effort.

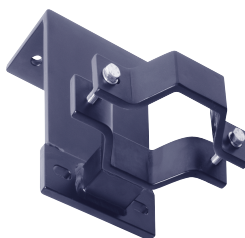

Ceiling column fitting (MUDEK)

The fitting is screwed onto the ceiling. To attach the stand below either a wall or floor fitting is necessary.

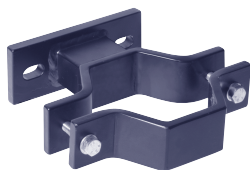

Wall column fitting (MUWAN)

At least two wall fittings are necessary to attach the stand.



Floor column fitting (MUBOD)

The holder is screwed onto the floor; the stand is then put over the cylinder. To attach the stand above either a wall or ceiling fitting is necessary.

FOBA®

STUDIO TECHNOLOGY

FOBA AG
Studio-Technology
Friedgrabenstrasse 21
CH-8907 Wettswil
Switzerland

☎ +41 44 701 90 00
☎ +41 44 701 90 01

info@foba.com
www.foba.com

For more information ask for
our brochure FOBA STUDIO STANDS
or call +41 44 701 90 00

FOBA product lines:

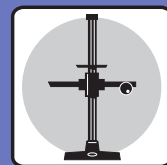

FOBA STUDIO STANDS, TRIPODS
FOBA STATIVE
FOBA PIÈDS À COLONNE, TRÉPIÈDS



FOBA TRIPOD HEADS
FOBA STATIVKÖPFE
FOBA TÊTES DE TRÉPIÈDS

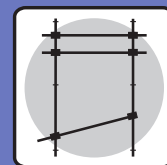

FOBA CEILING RAIL SYSTEM
FOBA DECKENSCHIENEN-SYSTEM
FOBA SYSTÈME RAILS DE PLAFOND

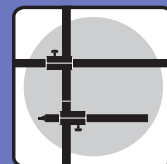

FOBA COMBITUBE SYSTEM
FOBA COMBIROHR® SYSTEM
FOBA SYSTÈME COMBITUBE



FOBA SHOOTING TABLES
FOBA AUFNAHMETISCHE
FOBA TABLES DE PRISE DE VUE

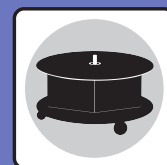

FOBA TURNTABLES
FOBA DREHTELLER
FOBA TABLES TOURNANTES